

175000-200000

LOAD CHART

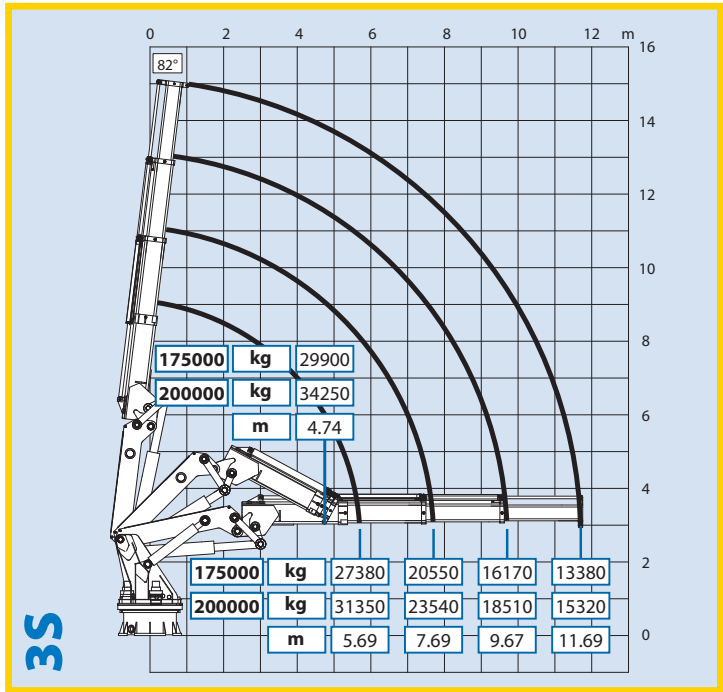

TECHNICAL CHARACTERISTICS

Description	u.o.m.	2S	3S
Max. hydraulic outreach	m	9,56	11,69
Capacity at max. outreach (175000)	kg	16800	13380
Capacity at max. outreach (200000)	kg	19230	15320
Slewing arc	(°)	360 / unlimited	
Slewing moment*	kNm	240	
Working pressure	bar	290/330	
Recommended oil delivery	l/min	120/65	
Weight of the standard crane (± 2%)	kg	11500	12800

*The technical data refers to the version with two slewing systems

NOTE: The boom versions and accessories mentioned in this brochure are not the only options available. Lifting capacities are based on the maximum lifting power of the crane. The stability of the crane's base or the installation of some accessories may require derating of the crane. For the complete data and more technical details on the crane performances and operation you are kindly invited to look in the 'Info-tech' section available at your nearest Effer dealer or to download them from the website www.effer.it.



NOTE: Technical modifications may change the stated data.

TECHNICAL DESCRIPTION

- Design according to DIN 15018/H1 B3 – Integrated by 5°/2° Heel/Trim
- Full fabricated construction with high-grade steel S 690 and S 890
- All steel components shotblasted and protected with zinc primer and marine painting cycle
- Slewing ring with double-race ball-bearing driven by double reduction gear unit
- Continuous slewing
- Operator platform with seat for top controls
- Full proportional controlbank with modular elements prearranged for winch installation
- Load moment limit device
- Prearranged support plates for winch mounting (below and over outer boom)
- Up to three hexagonal extensions with single stage cylinders with marine chrome coating
- Knuckle cylinder with stainless steel rod and marine chrome coating
- Hose end fittings protected with heat shrunk shroud
- Stainless steel pipes with stainless steel fittings
- Double special hydraulic circuit (model 200000 only)

Mod: 175000 - 200000 - Data: 17-05-2007 - Rev. 00

AVAILABLE OPTIONS

- Mechanical extensions stowable in the boom
- Triple slewing system
- Full proportional controlbank with modular elements prearranged for variable pump and radio remote controls
- Winch up to 6000 daN capacity installed under the 2nd boom
- Winch up to 10000 daN capacity installed on the 1st or 2nd boom
- End stroke device + Emergency stop
- Stainless steel pipes with stainless steel fittings
- Up to 2 supplementary controls for hydraulic accessories
- Centralized greasing

www.inprima.it

OVERALL DIMENSIONS

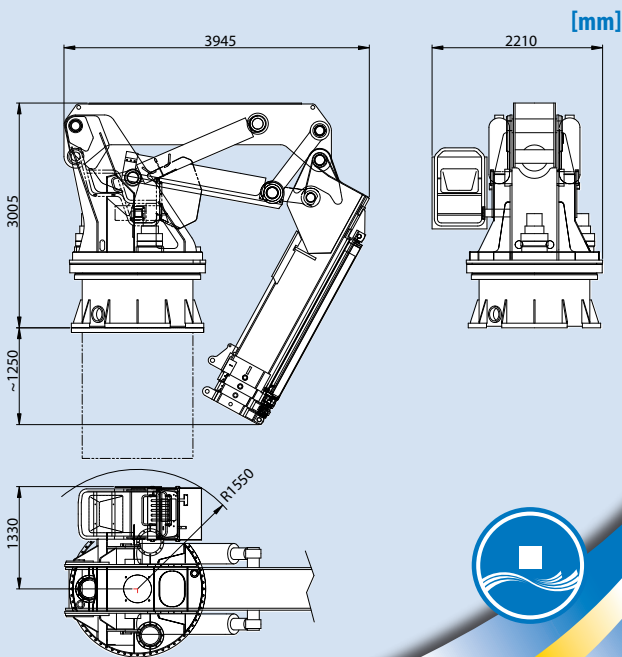

3S

